

(RESIDENTIAL USE ONLY)
BEST MANAGEMENT PRACTICE
ROCK SLOPE PROTECTION

NOTE: ROCK SLOPE PROTECTION DOES NOT PROTECT AGAINST MASS MOVEMENT OF EARTH OR LANDSLIDES.

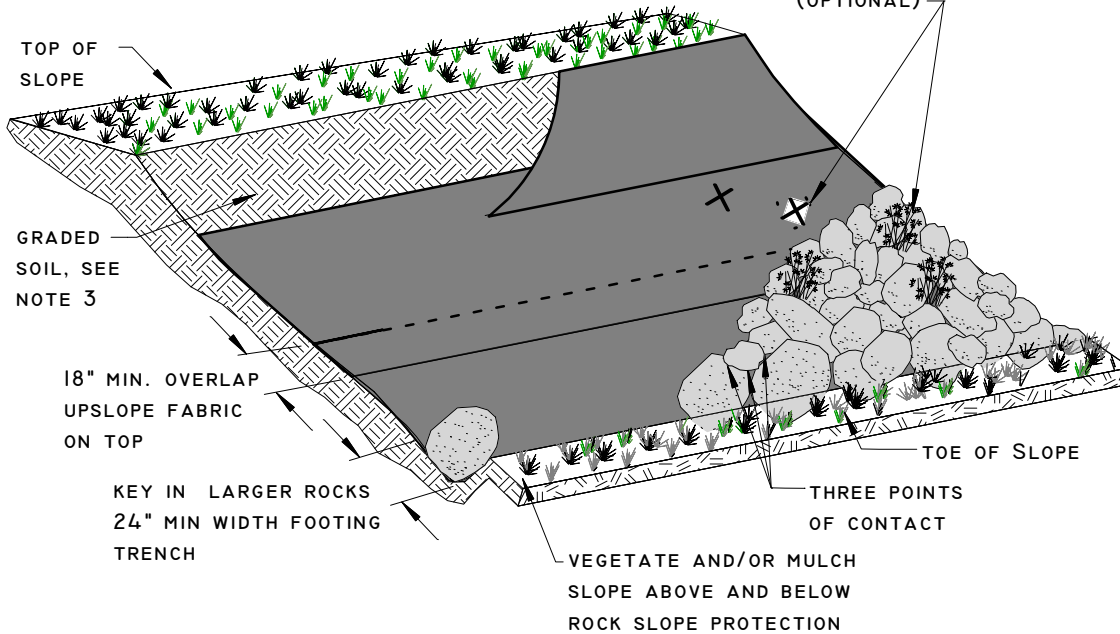

CONSTRUCTION NOTES

1. ROCK SLOPE PROTECTION WITH FILTER FABRIC APPLIES TO SLOPES WHERE CONCENTRATED FLOW IS EXPECTED OR SEEPAGE WILL OCCUR. ALTERNATIVELY, USE STANDARD DRAWING BMP-040 "ROCK SLOPE PROTECTION (NO FABRIC)" AS APPLICABLE. CONSULT ENGINEER TO ENSURE APPLICABLE DESIGN REQUIREMENTS ARE MET.
2. ROCK SLOPE PROTECTION PRACTICE IS INTENDED FOR SLOPES TOO UNSTABLE FOR REVEGETATION PRACTICES ALONE. MAXIMUM SLOPE 1.5:1 HORIZ:VERT, (67% OR 34°) OR FLATTER, AND IS LIMITED TO SLOPES < 30' OF UNINTERRUPTED LENGTH.
3. PREPARE SLOPE BY REMOVING INVASIVE SPECIES, FALLEN OR HAZARDOUS TREES, ROCKS OR OTHER DEBRIS. FLATTEN SLOPE AS NEEDED TO PROVIDE A SUITABLE GRADE. BEGIN INSTALLATION BY TRENCHING ALONG THE TOE OF THE SLOPE.
4. PLACE FABRIC STARTING AT THE TOE AND OVERLAP 18" WITH UPSLOPE FABRIC ON TOP. PLACE STAPLES AS SHOWN IN DETAIL. IN LIEU OF FABRIC, A FILTER LAYER OF GRAVEL OR SAND MAY BE USED.
5. HAND PLACE THE LARGEST ROCKS IN THE TRENCH FIRST TO FORM A SOLID ROW AS THE FOUNDATION.
6. PLACE ROCK IN A MANNER THAT IS UNIFORMLY DISTRIBUTED AND FIRMLY IN CONTACT ONE TO ANOTHER WITH SMALLER ROCKS FILLING THE VOIDS BETWEEN THE LARGER ROCKS. HAND PLACEMENT OF SOME ROCK MAY BE REQUIRED ADJACENT TO EXISTING STRUCTURES TO PREVENT DAMAGE AND TO ACHIEVE THE FINAL FINISHED SURFACE.
7. OVER-SEED TO ENCOURAGE VEGETATION IN ROCK INTER SPACES. REFER TO NRCS "SLOPE STABILIZATION USING VEGETATION" TIP SHEET FOR MORE INFORMATION.

INSTALLATION GUIDELINES

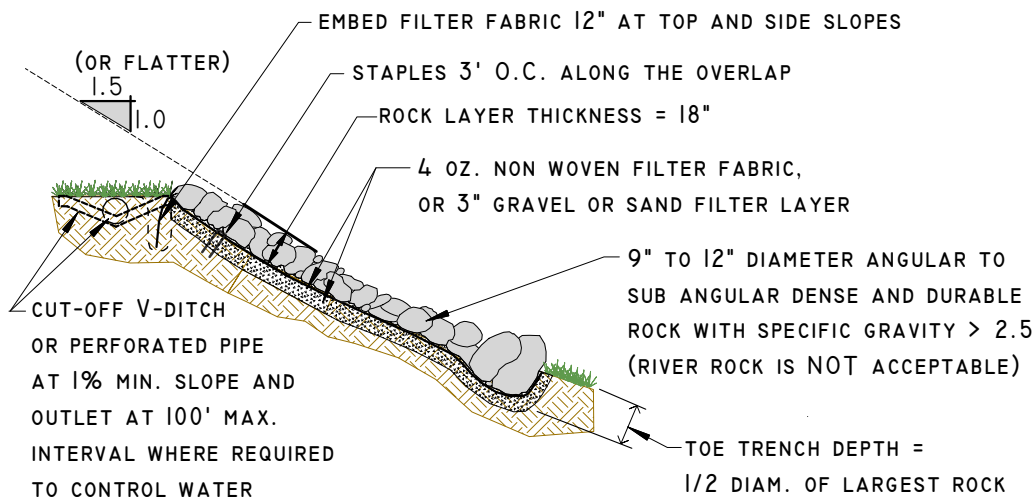

U.S. DEPARTMENT OF AGRICULTURE		
NATURAL RESOURCES CONSERVATION SERVICE		
IN COOPERATION WITH		
TAHOE RESOURCE CONSERVATION DISTRICT, AND NEVADA TAHOE CONSERVATION DISTRICT		
DRAWN BY:	APPROVED BY:	DATE
DMGG/CLT		

THIS STANDARD DRAWING IS BASED ON A REFERENCE TO THE NRCS CONSTRUCTION SPECIFICATION 907 - ROCK RIPRAP AND NRCS STANDARD PRACTICE 342 - CRITICAL AREA PLANTING. THIS DRAWING IS INTENDED TO ASSIST THE DESIGNER IN PREPARATION OF A COMPLETE SITE SPECIFIC DESIGN, AND IT IS NOT TO REPLACE THE INDEPENDENT JUDGMENT AND ANALYSIS BY A QUALIFIED DESIGNER.